

# ***PAINTBALL MARKER OPERATION MANUAL***

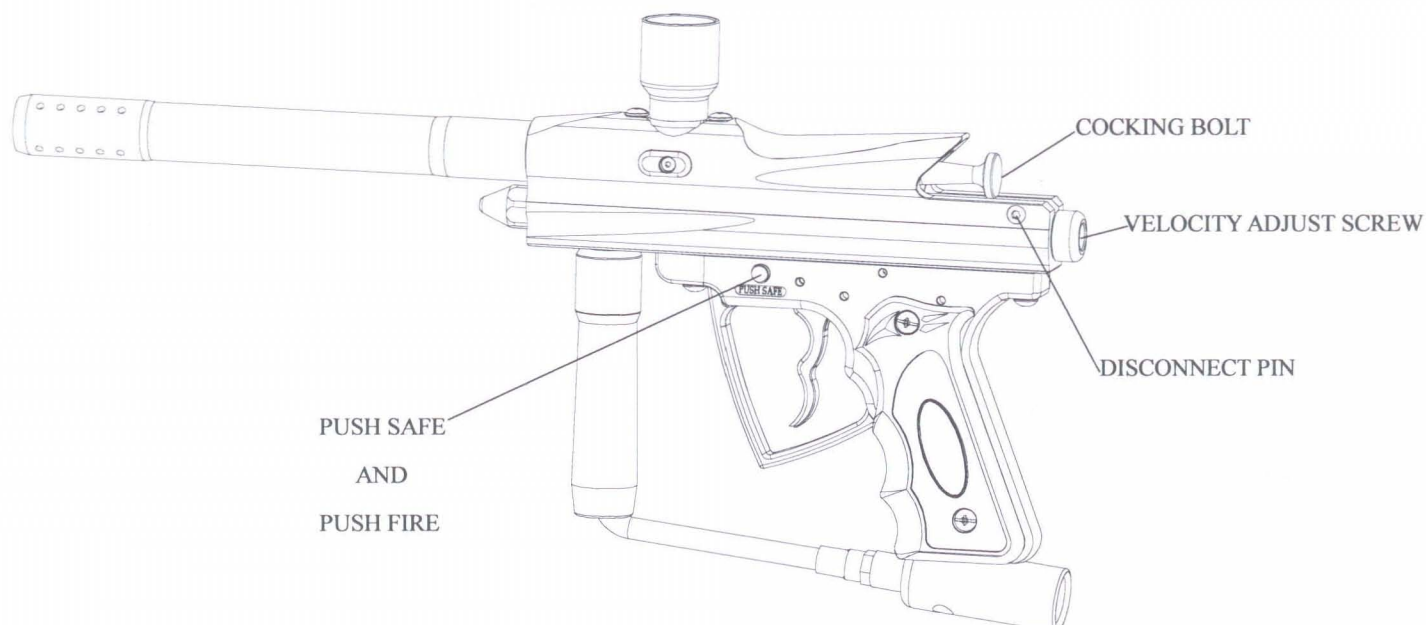

## ***READ OWNER'S MANUAL BEFORE OPERATING***

***THIS IS NOT A TOY.*** MISUSE MAY CAUSE SERIOUS INJURY OR DEATH. EYE PROTECTION IS DESIGNED SPECIFICALLY FOR PLAYING PAINTBALL AND MUST BE WORN BY USER AS WELL AS ALL PERSONS WITHIN RANGE. RECOMMEND 18 YEARS OR OLDER TO PURCHASE. PERSONS UNDER 18 MUST HAVE ADULT SUPERVISION.

## ***WARNING***

1. Use only CO<sub>2</sub>/ Nitrogen/Compressed Air.
2. To put marker on SAFE, push the safety from the “push safe” side of the trigger frame. Before you turn ON your air source. To disengage the safety, push in the safety from the “push fire” side of trigger frame.
3. Do not exceed **900 psi** inlet pressure into this marker.
4. When not playing with and storing the marker for an extended amount of time, disconnect the air source to prevent damage marker.
5. Fire only 0.68 caliber paintballs from this product.
6. This product is intended to be used at a velocity no greater then 300 feet per second.
7. This product is not intended to be used at any distance less then 25 feet.

## ***QUICK START/OPERATION GUIDE***

1. Screw on the barrel. then place a barrel plug over the end of the barrel.
2. Screw your air source into the paintball marker bottom line. Using CO<sub>2</sub>/Nitrogen/Compressed air, simply screw your tank in until it seals. Place your hopper into the marker feed tube. Now add paintballs.
3. Making sure your goggles are on, remove the barrel plug. Making sure the safe button at safe position.
4. Cook the marker by pulling the cocking bolt rearward until it latches.
5. The marker is now ready for play. With the safety off, fire the marker by pulling the trigger. Follow all safety regulations and rules before beginning and during play. **NOTE:** To degas the marker properly and prevent damage to your bottle O-ring, turn the bottle out slowly as you cycle the marker after you have removed the hopper and paintballs. Make sure that there are no paintballs in the marker breach, and point the barrel towards the ground with a barrel plug on during removal.

## DISASSEMBLY/MAINTENANCE/CLEANING/REASSEMBLY

1. Only use lubrication specifically designed for paintball markers. To lubrication your marker, you will need to disassemble.
2. Remove the disconnect pin (19). Hold down the striker plug (29) and thumb adjuster, as internal parts may be spring loaded. As you pull the cocking knob out of the body, the cocking bolt (20) and striker (24) will also be removed.
3. Lubricate bolt O-ring (21) and striker O-ring (21) with a few drops of paintball oil only. Too much oil with striker O-ring may will not re-cocking.
4. Reassemble parts back into the marker. After putting the bolt and striker back into the body, need to apply pressure behind the bolt while pulling the trigger at twice, this will allow the bolt and striker to be properly installed back into the body.

## TROUBLESHOOTING

ONE OR MORE OF THE FOLLOWING MAY CAUSE RECOCKING RELATED PROBLEMS:

1. The pressure in tank is too low.
2. Need to clean barrel and upper chamber or striker O-ring is damaged need replace or need lubrication.
3. Paintball may defective (i.e. expired, change shape). After ball breaks, remove all parts wipe parts clean and reassemble.

## HELPFUL HINTS

1. The marker air leaks are usually cause damaged valve body or cup seal. Replace with new if necessary.
2. Do not remove the valve body unless specific valve body repair are needed. If needed, remove body with a long soft-tipped object such as the eraser end of a pencil.
3. To assure marker is assembled properly, follow the schematic drawing.

## ASSEMBLY DIAGRAM

